



*A trusty workhorse  
to achieve your goals with*

A versatile, flexible and resilient platform to fit customized bodies and superstructures, comes in different wheelbases, cabin and seating arrangements to suit different needs.

The SMT55 chassis cab is a compact designed truck to guarantee maximum off road capability.

The cabin, with standard power windows, provides exceptional visibility to the driver thanks to its wide windscreen and short bonnet.

Compact dimensions go together with the spacious interior for a comfortable feel even in the harshest conditions.

### FRAME

The backbone of SCAM trucks is the heavy duty, straight ladder-type frame with cross-members. With its double "C" channel design it's able to withstand the toughest jobs yet maintaining good flexibility and torsion.

Full flat top surface, gives to the body-builders plenty of freedom and gives the frame extraordinary versatility in adapting many configurations and requirements.

Powder painting, cataphoresis process ensure long lasting protection.

### SUSPENSION

A simple, but performing, leaf spring suspension system offers unrivalled capability in carrying personnel and loads, and easing field maintenance. For enhanced stability and optimum on-road handling, all SCAM vehicles are factory fitted with both front and rear torsion bars.

Stout, simple solid axle beams, unlike independent suspensions, allow the vehicle to keep constant ground clearance on uneven terrain, reducing the risk of hang-ups.

### POWERTRAIN

SCAM Chassis-Cowl is equipped with reliable engine, power take-offs and lockable differentials. These are some of the many reasons why SCAM chassis-cowl is a capable platform to build on and develop your business with.

The choice of a popular turbo diesel engine, coupled to manual six speeds gearbox, means after sale service and easily sourceable spares, even in the most remote corners of the globe. The unique SCAM 4-speed transfer case offers 24 gears to the driver bringing uncompromised ability to crawl over the most demanding obstacles.

### PERFORMANCES

Performances are of paramount importance at SCAM; extremely favorable approach and departure angles, generous ground clearance, 100% gradeability and supple parabolic leaf springs; all ensure high mobility and comfort. The wide tracked, heavy duty axles keep the SCAM planted and stable on roads as well as on steep slopes.

### OPTIONALS

Air conditioning is available as well as useful accessories like snorkel, bullbar, winch and specific equipments for various environments and purposes.

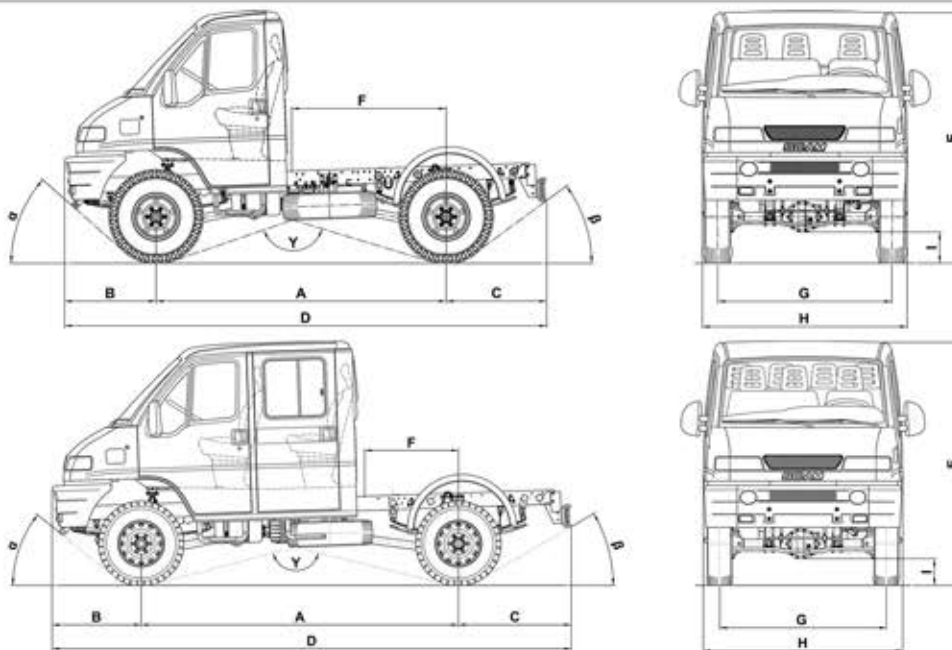

**SCAM**

SMT55 CHASSIS CAB

A TRUSTY WORKHORSE TO ACHIEVE YOUR GOALS WITH

## GENERAL

Fuel tank (liter)	70
GAWR, f/r (kg)	2450-3700
Electrical system (V)	12
GVW (kg)	5500
Tyres (standard)	255/100 R16
Tyres (optional)	9,5 R 17,5

## PERFORMANCE

	S28	S32	D32	S35	D35
(α) Approach angle	42°	42°	42°	42°	42°
(β) Departure angle	38°	32°	32°	32°	32°
(γ) Ramp Angle	148°	151°	151°	154°	154°
Payload (kg)	3100	3050	2810	3000	2760
Turning radius (m)	6,30	6,70	6,70	7,10	7,10
Curb weight (kg)	2400	2450	2690	2500	2740
Gradeability (*)	100%	100%	100%	100%	100%
Side slope (*)	35°	35°	35°	35°	35°
Fording depth (mm) (**)	660	660	660	660	660

(\*) depending on final configuration

\*\* with optional wading kit

## CABIN

Semi-forward type, single cabin (2 doors, 3 seats) or crew cabin (4 doors, 7 seats) including driver. Complete metallic body. Power windows. Adjustable driver seat, safety belts, tool box. Cab ventilation & heating system. Glove compartment on the doors and dashboard. Instruments according to vehicle functions and EEC norms.

## DIMENSIONS

	S28	S32	D32	S35	D35
Cabin	Single	Single	Crew	Single	Crew
[A]WB (mm)	2850	3200	3200	3550	3550
[B]Front Overhang (mm)	900	900	900	900	900
[C]Rear Overhang (mm)	960	1110	1110	1110	1110
[D] Length (mm)	4710	5210	5210	5560	5560
[E]Height (mm)	2420	2420	2510	2420	2510
[F]Cabin/rear axle distance	1500	1850	950	2200	1300
[G]Front/rear track (mm)	1700	1700	1700	1700	1700
[H]Width (mm)	1998	1998	1998	1998	1998
[I] Ground clearance (mm)	280	280	280	280	280

## POWERTRAIN

Make	IVECO
Type	TURBO DIESEL 8140.43N EURO 3
Max Power	146 hp - 107 kw @ 3600 RPM
Max torque	320 Nm @ 1500 RPM
Gear Box Type	ZF Manual 6+1
Transfer Type	Full 4x4 Lockable - 4 speed
Differentials	Lockable front, central and rear

## SUSPENSION

Parabolic leaf springs with torsion bar. Hydraulic telescopic shock absorbers. Double flexibility rear leaf springs to enhance comfort.

IMPORTANT NOTICE: ACCORDING TO THE CONTINUOUS IMPROVEMENTS OF SCAM POLICY, ALL SPECIFICATIONS ARE SUBJECT TO CHANGE WITHOUT NOTICE.  
THE PICTURES ARE FOR ILLUSTRATIVE PURPOSE ONLY

**SCAM**

SCAM S.r.l. - Part of Certina Group® - Via Campagna, 80 - 21056 Induno Olona (VA) - Italy  
Tel: +39 0332 202861 - Fax: +39 0332 202252 - email: info@scamtrucks.it - [www.scamtrucks.it](http://www.scamtrucks.it)

Version 02/2015